

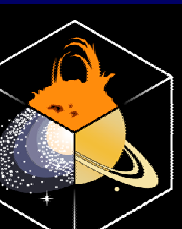

# ASSERT

## Argos Spectrometer Search for Extragalactic Radio Transients



ETH Zurich  
Institute of  
Astronomy

Christian A. Monstein  
Institute of Astronomy  
Wolfgang-Pauli-Strasse 27  
8093 Zürich  
Switzerland



# What are we looking for?

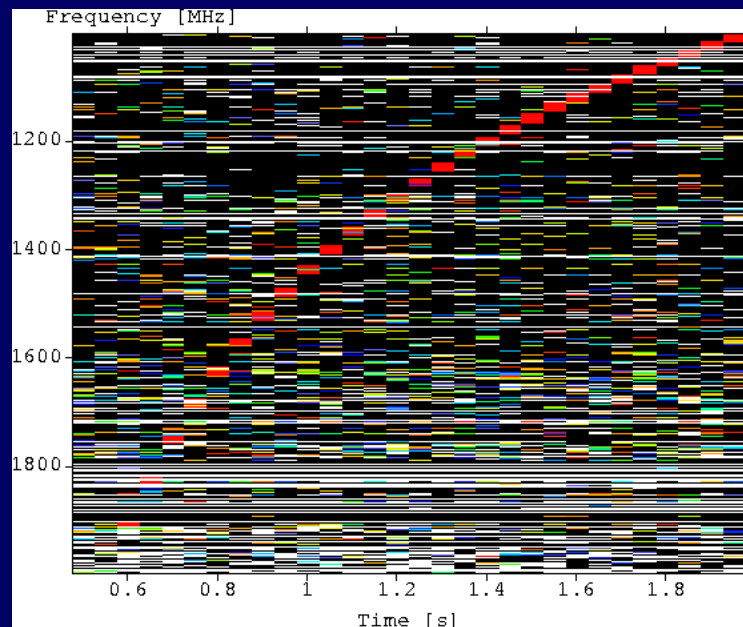
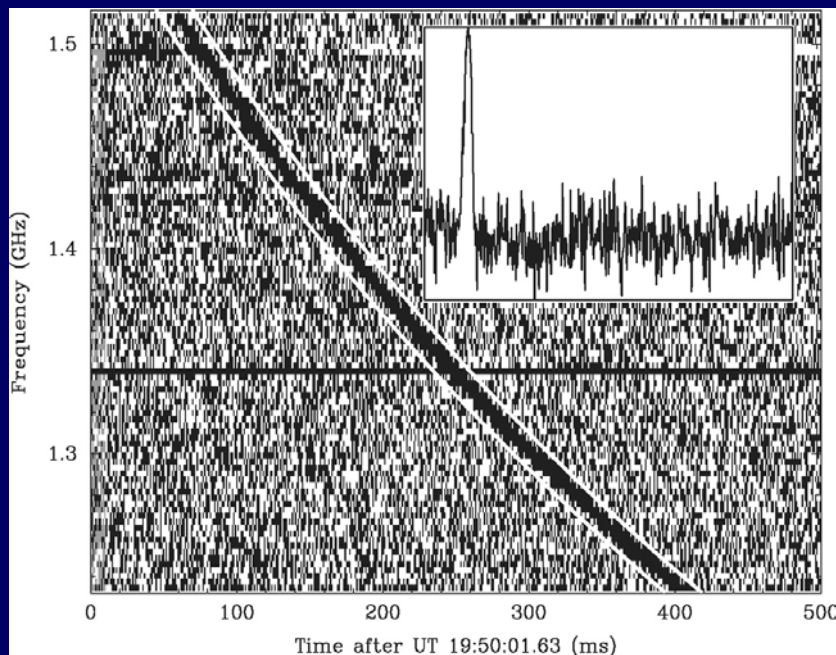

A Bright Millisecond Radio Burst  
of Extragalactic Origin  
D. R. Lorimer et. al. 2007

Our fake burst of 30 Jansky on  
top of a real spectrum of the sky  
to test IDL detection procedures



# Specification Spectrometer

<u>Parameter</u>	<u>Specification</u>
Frequency range	1.0 GHz – 2.0 GHz (Bandfilter 1150 MHz - 1750 MHz)
Frequency resolution	61.0 KHz
Radiometric bandwidth	90 KHz @ -3 dB (due to Blackman-filter)
Dynamic range	~ 24 dB
Noise figure	1.8 dB
Time resolution	10 msec
Number of channels	16'384
Numerical resolution	32 Bit
Data rate	6.55 MByte/sec or 566 GByte/day
Power consumption	120 Watt



# Field test of horn



Left: Andreas James is setting up the receiver

Top: Transport of L-band horn in a VW



# Heterodyne Receiver

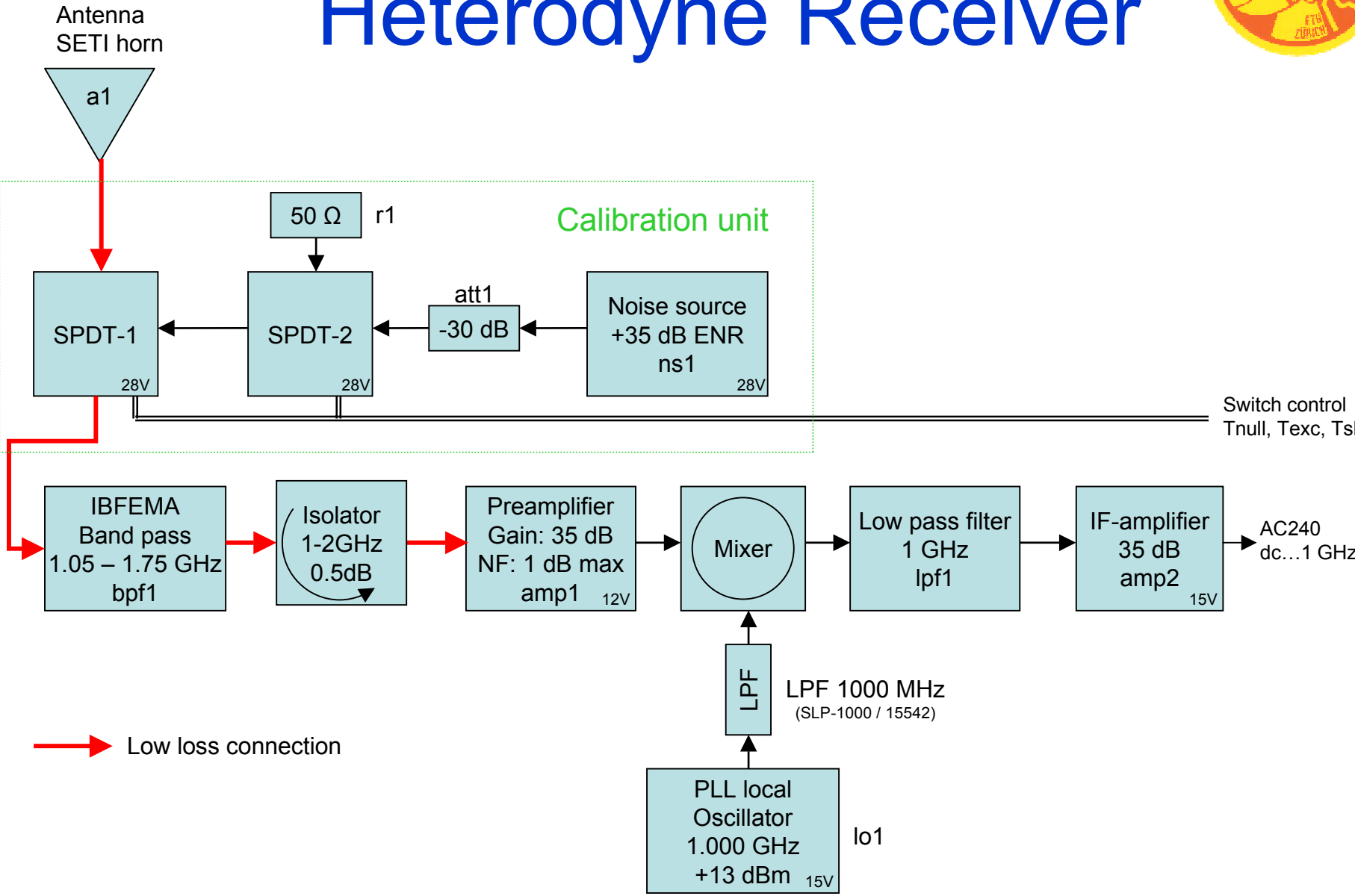



# Frontend hardware

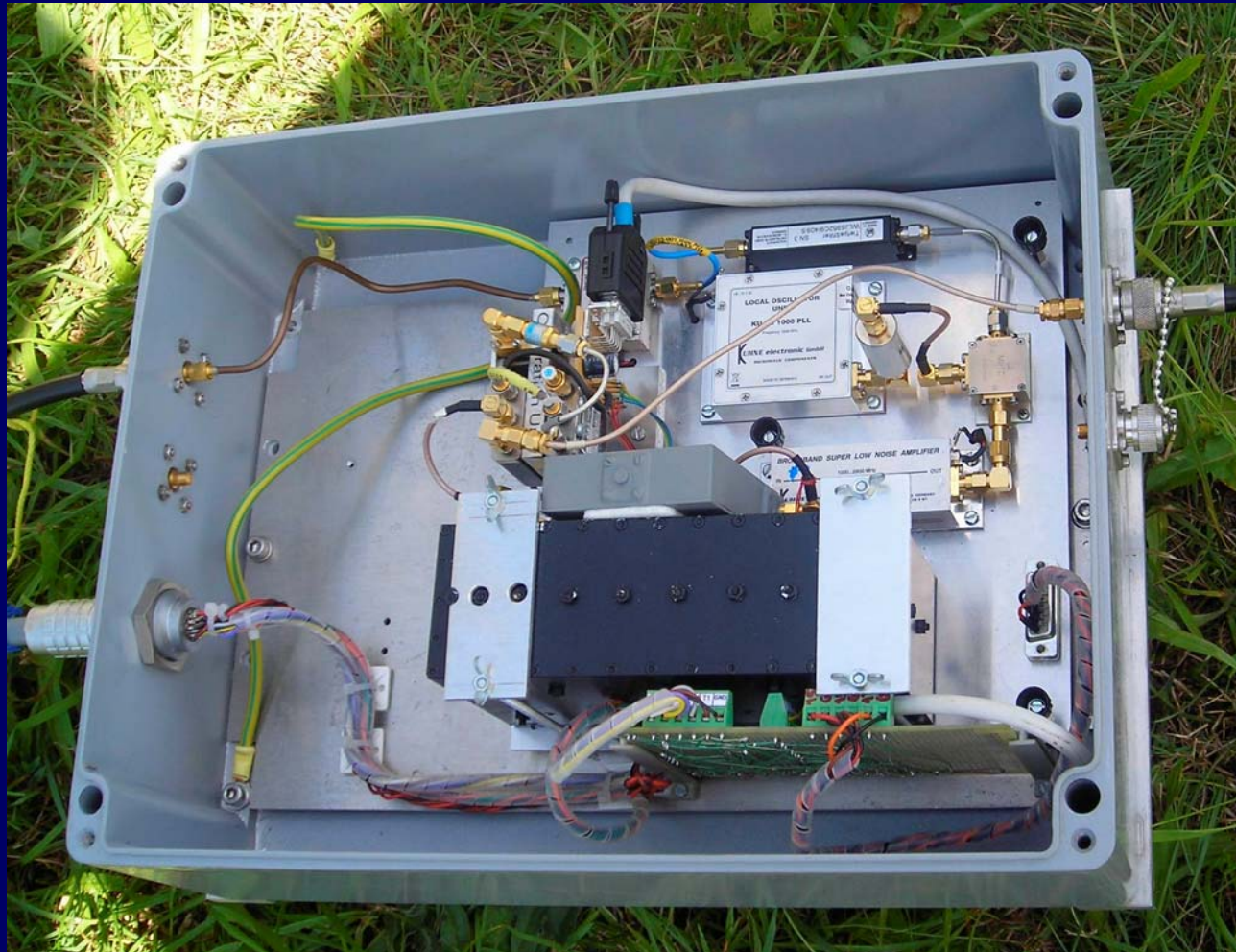



# Backend hardware

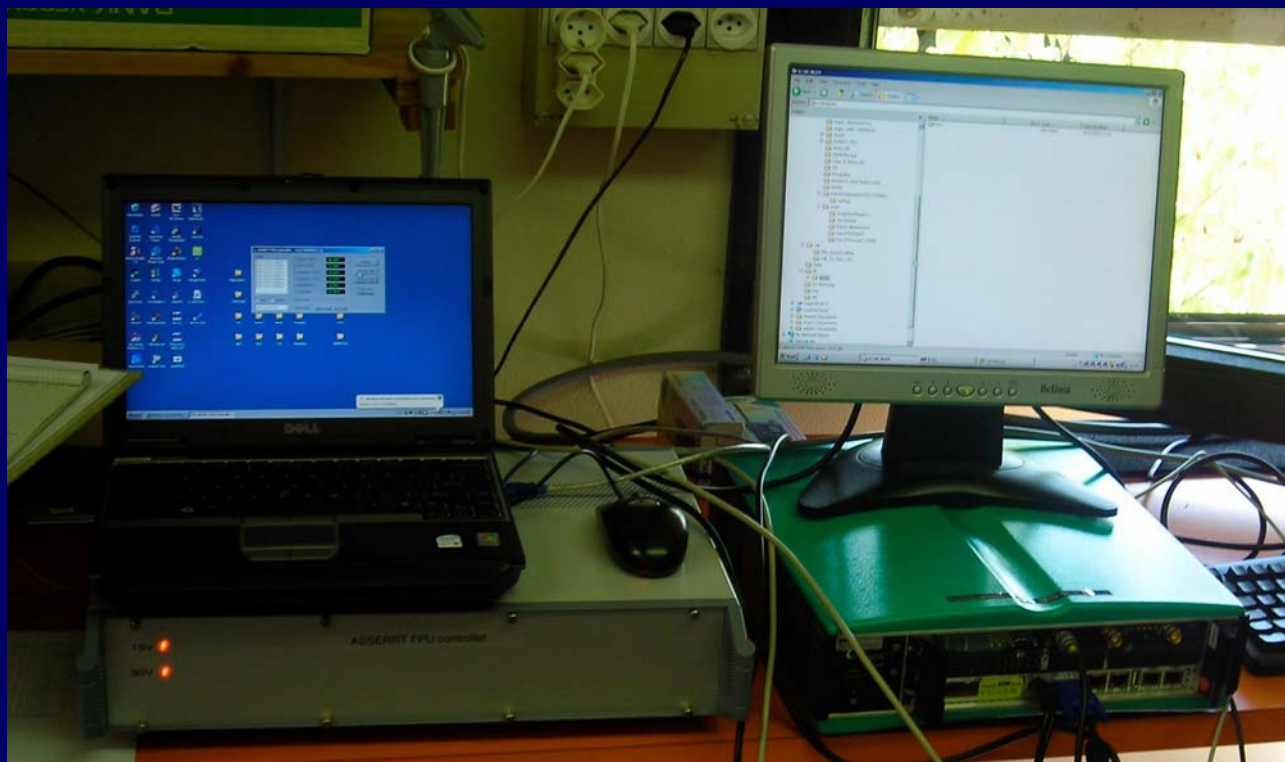

Frontend PC  
Frontend controller  
and receiver power supply

FFT - spectrometer  
including industrial PC



# Results

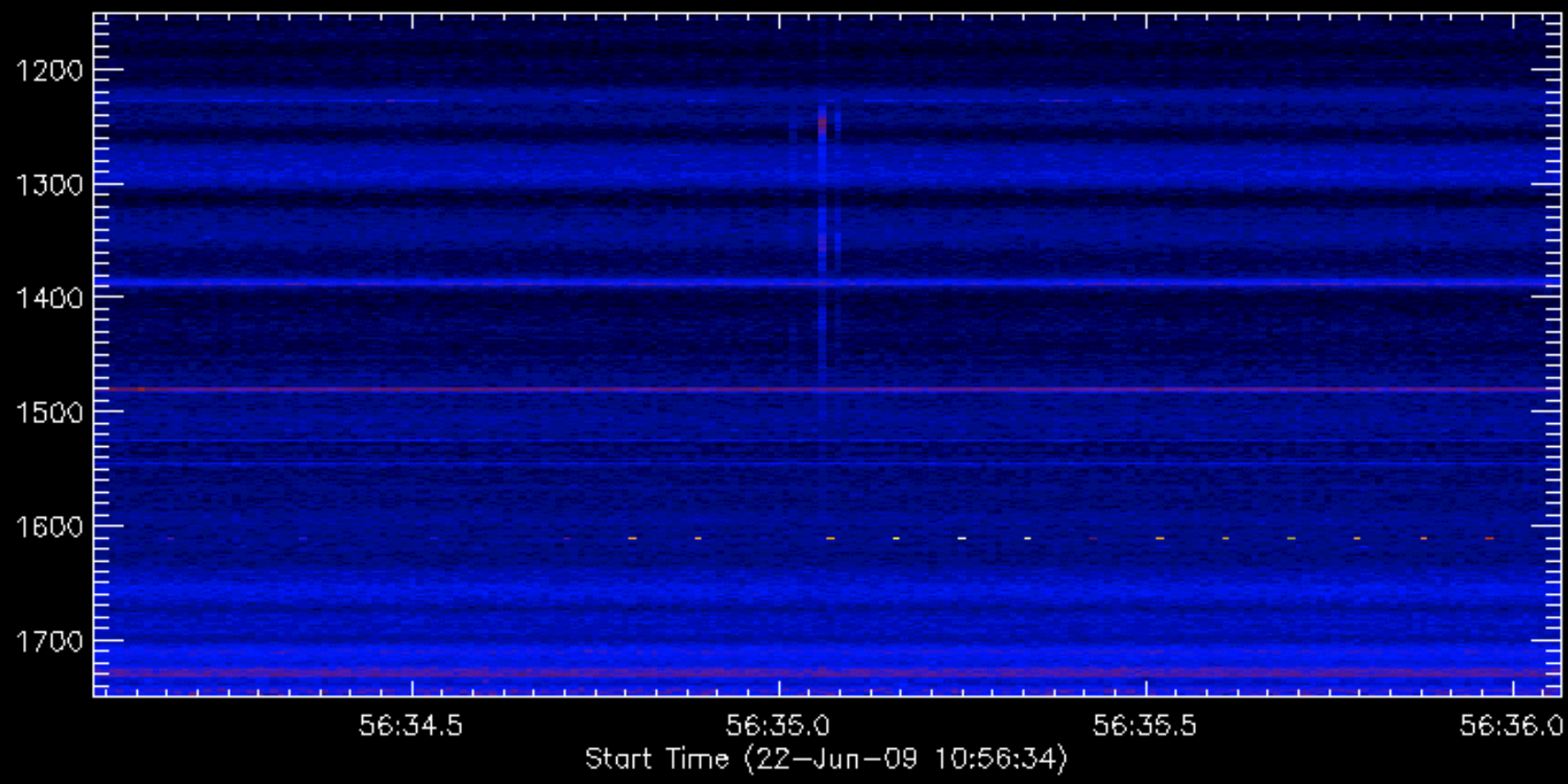

Probably lightning flash with echo